



Phil Jones Bass

PJB SUPER FLIGHTCASE



OWNER'S MANUAL

Thank you for purchasing the PJB SUPER FLIGHTCASE. A great deal of dedication and passion went into designing and building this no compromise, high performance compact-combo amplifier. It was conceived to be a dedicated amplifier for the “connoisseur” bassist. Reading this manual will enable you to get the best performance from it so that you may enjoy many years of service.

READ THIS FIRST

- **Before using the SUPER FLIGHTCASE please read ALL the instructions.**
- **On receipt of product, check for any signs of physical damage arising from shipping. If any damage is visible contact your dealer.**
- **Keep all original packing.**
- **Never use this product in the vicinity of water. If the SUPER FLIGHTCASE were to get wet, it could kill you by electrocution.**
- **Do not use this amplifier in a way that would compromise its ventilation system. When operating, never cover the heat sink on rear panel.**
- **Do not locate this amplifier near any heat source.**
- **This amplifier must be connected only to a power source specified in this manual.**
- **For safety do not leave the amplifier plugged into a power source for long periods of time when not in use.**
- **Do not let any liquid or foreign objects fall into any openings on the amplifier.**
- **Never use this amplifier if it has:
 1. Suffered any physical damage.
 2. Been subjected to any liquids, rain or moisture.
 3. Damaged cables connected to it.If any of the above occurs, the amplifier should be examined by qualified service personnel.**
- **Always operate this amplifier with the correctly rated fuse. Never use this amplifier without proper grounding.**

OVERVIEW OF THE SUPER FLIGHTCASE

Never has amp existed for a bass player, that is so light, versatile and as high performance as The SUPER FLIGHTCASE .It is so unique it has two patents applied for. PJB has invested a massive amount of resources to develop advances in digital amplifiers for bass and string instruments and ultra powerful lightweight new generation Neodymium loudspeaker units to bring an amplifier to world of bassists who appreciate high performance yet demand compact and lightweight amplification.

The six 5 inch proprietary PJB drivers have been acoustically optimally loaded by precise computer analysis to provide a full-range, dynamic sound that can play down to an open B and yet give every single harmonic startling definition so the amplifier becomes one with the player.

This amplifier is designed to be placed on the ground and yet deliver full range sound in great detail to both players and audience without the need of tilting back or being placed off the ground, which can rob the amp of low frequency reproduction.

AMPLIFIER FEATURES

- Dedicated Active or Passive input stage.
- 5 Band EQ
- Balanced Line Output with ground lift.
- Sophisticated protection circuitry
- 250watt RMS Amplifier
- Ultra low noise pre amplifier circuit.

FRONT PANEL OVERVIEW

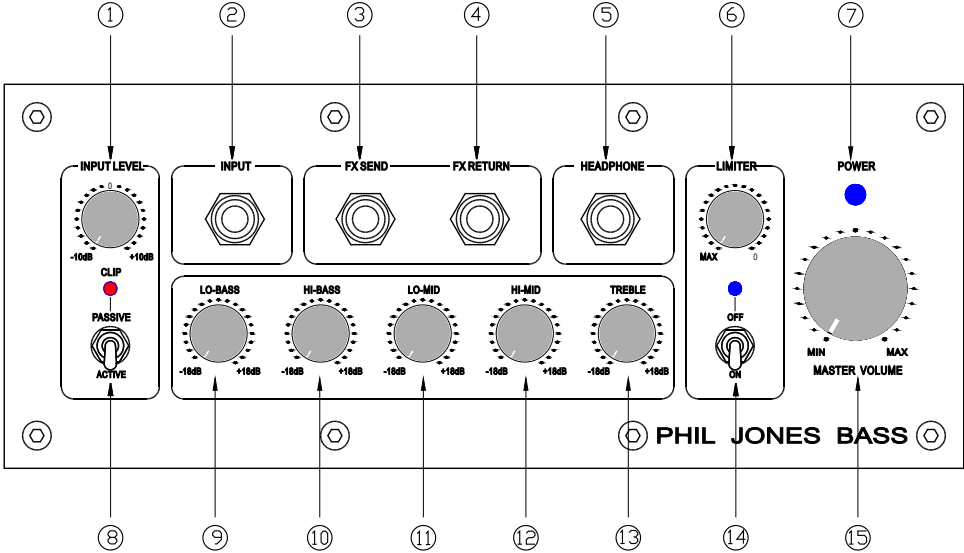

BACK PANEL OVERVIEW

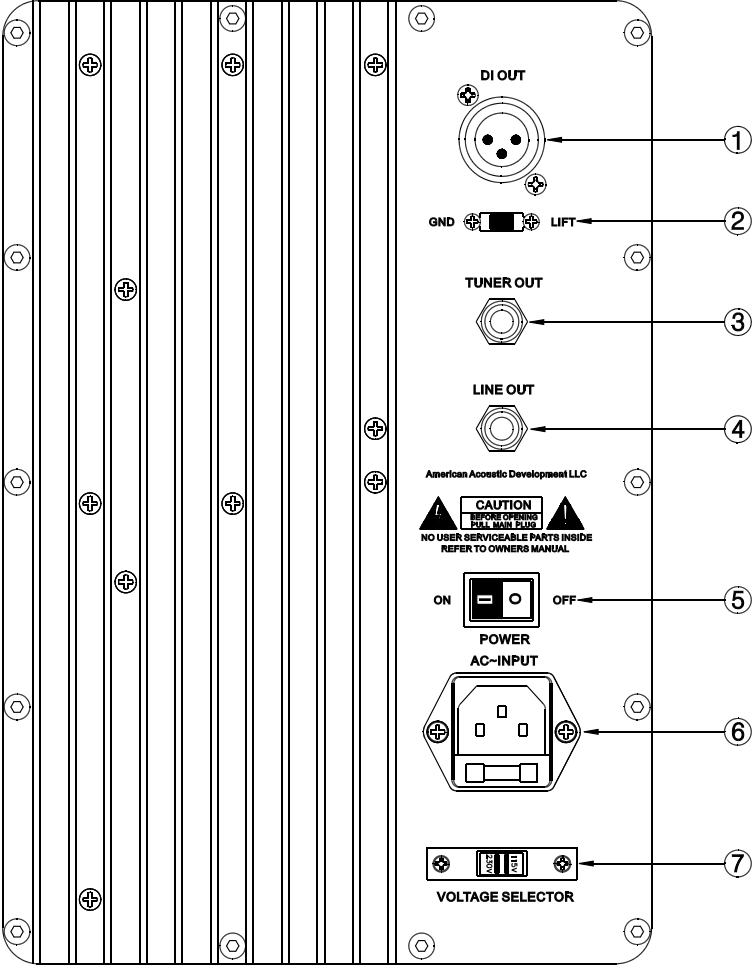

FRONT PANEL DESCRIPTION

1. INPUT LEVEL SENSITIVITY

2. INSTRUMENT INPUT SOCKET

This is a standard ¼ inch mono jack socket.

3. FX SEND SOCKET

Connect the FX send to auxiliary FX unit input.

4. FX RETURN SOCKET

Connect the FX Return to auxiliary FX unit output.

5. HEADPHONE SOCKET (STEREO PHONES)

This jack accepts ¼ inch stereo headphone jacks. *When a headphone is connected to the jack, the speakers will be disconnected and therefore no sound from them.*

6. COMPRESSOR THRESHOLD LEVEL CONTROL

This will vary the level the limiter threshold. The compression ratio is 3dB to 1. Adjust this to suit your playing style and output power of your instrument. The blue LED will light up when the signal is being compressed. This will vary on how hard the instrument is played and how the threshold is adjusted.

7. POWER INDICATOR.

8. ACTIVE / PASSIVE INPUT SWITCH

This switch allows you to match the SUPER FLIGHTCASE to match either active or passive basses. **PASSIVE** - Higher sensitivity, high impedance input (450mV/4.7MΩ). For bass instruments that do not have active electronics, suited for older 'vintage' basses. This setting is precisely matched to high impedance pickups enabling them to faithfully reproduce the true frequency and dynamic range of the instrument.

ACTIVE- Lower sensitivity input setting (1.4V) for basses with onboard electronics. Input matched for low signal to noise ratio and optimum transfer of electrical signal from modern high-end basses.

9. LOW BASS EQ CONTROL

This will adjust the fundamental tones of E and A strings on 4 string basses and B, E & A on 5 string basses.

10. HIGH BASS EQ CONTROL

This will adjust the fundamental tones of D and G-strings on 4 & 5 string basses.

11. MID RANGE EQ CONTROL

12. LOW TEBLE EQ CONTROL

13. HIGH TREBLE (PRESCENCE) EQ CONTROL

14. LIMITER IN/OUT SWITCH Sends signal through limiter or bypass.

15. MASTER VOUME CONTROL

This is the master volume control and it controls how much power you send to your speakers as well as the line out socket on the back of the amp. When setting up your tone or plugging in your instrument, you should keep this control at a low level. All instruments are different when it comes to how much output is from the pickups. Likewise for players, depending on how hard or soft you play.

BACK PANEL DESCRIPTION

1. BALANCED LINE OUT

This is an ultra-low impedance (200Ω) balanced line out for use with recording or PA mixing consoles. This output is not controlled by the volume control. Changing the level on your instrument will however, vary the DI output.

2. GROUND LIFT SWITCH

This allows the grounding of balanced out socket to be disconnected. This is useful if you are experiencing hum caused by grounding loops/problems.

3. LINE OUT

Can be used for driving a second amplifier.

4. TUNER OUT

Connect to instrument tuner. This output can also be used as an additional line out.

5. POWER ON/OFF SWITCH

This switches the main power on and off in the amplifier. When you turn on the power, it will have about 2 seconds delay to protect the speaker.

Do not leave the amplifier plugged into a power source for long periods of time when not in use.

6. AC INPUT SOCKET & FUSE.

Connects the amplifier to AC power supply. Always use a grounded plug and make sure the AC cable is more than 3A rating at 250-volt AC. If you require a longer AC power cord, we recommend the PJB heavy-duty 20 foot power cords. These are available as an accessory. If fuse needs replacing, use a slow blow ¾ inch fuse rated at 2.5 amps.

7. AC INPUT -VOLTAGE SELECTOR.

Switches the amplifier to run on either 110-120 volt or 220-240 volt AC power. **Never try to run the amplifier on a 220-240 volt supply when switched to 110-120 volt. This can possibly cause major damage to the amplifier.**

OPERATION & POSITIONING

TURN THE VOLUME DOWN on the SUPER FLIGHTCASE before plugging in your instrument.

Positioning the SUPER FLIGHTCASE for Best Sound

Often, playing in different venues will cause your bass to sound different. This is partially due to the acoustics of the hall influencing the low frequency waves that are coming from your speaker. Bass waves are large and room dimensions heavily influence them when the walls reflect the sound waves, causing them to collide by adding together or canceling each other out. This causes some fundamental notes (the ones you feel more than hear) to ring out louder than others and some notes not to be heard at all.

Here is an indication of where fundamental bass frequencies are, showing open string's approximate frequencies and acoustic wavelength:

F# string	24Hz	46feet
B string	31Hz	36feet
E string	41Hz	27feet
A string	55Hz	20feet
D string	73Hz	15feet
G string	98Hz	11feet
C string	130Hz	9feet

This may give you some indication of the offending notes (frequencies) that may be booming or resonating louder or quieter than others. For example if your speakers are five feet from a wall, the open A string may sound weak. That could be because the path length of the reflected sound off the wall from your speaker is exactly corresponding to half a wavelength on the open A string causing at that particular note to cancel out.

Where you position the SUPER FLIGHTCASE will ultimately affect your low frequency limit. For best results keep the SUPER FLIGHTCASE on the floor. Placing it on objects off the floor will cause it to sound thin and lack bass punch. Placing the SUPER FLIGHTCASE with the back close to a wall will help reinforce the lower notes. Placing it in a room corner will further enhance the low notes.

Room size makes a large difference in how deep the bass will sound. The further the distance to the listener the less the bass will be. This is due to the physics of acoustics not the unit itself.

Unfortunately for bass players, low frequencies are always very difficult to control with room acoustics. The reproduced wavelengths of the notes you are playing often correspond to the room dimensions, in which case the reflected sound off the walls interferes with the sound from the speaker as you get further away from it.

Setting Up the Limiter

Although a limiter is not essential to bass amplification, it can be a useful tool in smoothing out the character of your instrument or playing style. The SUPER FLIGHTCASE limiter has a preset compression ratio of 3 to 1. For each additional increase of 3dB above the set threshold, the increase in level is actually 1dB. So the dynamic range of your instrument is reduced.

First set up the limiter by having the compression control (6) set fully clockwise. Now switch on the limiter (14). Start playing and turn control (6) counter-clockwise. You will see the blue light start to come on and that is the indication that the limiter is now working. Set this control to suit your taste.

TRANSPORTING AND STORING THE SUPER FLIGHTCASE

When transporting in a vehicle, it is recommended that you use an external case or heavy-duty cover to prevent it being damaged by falling over or other objects falling on it.

When Storing:

- Keep in a dry location preferably at room temperature.
- Do not store in temperatures below -20 Degrees C or above 40 Degrees C.
- Do not allow it to get wet. If this occurs, never turn it on in this condition.
- Do not leave the SUPER FLIGHTCASE permanently connected to a power source.

SPECIFICATIONS

Speaker

Computer Optimized Vented Enclosure

Speaker Frequency Response: 40Hz - 15KHz

Speaker Compliment: 6 x 5inch proprietary, extended-range drivers

Speaker Sensitivity: 94dB/W/M

Internal Speaker Impedance: 6 Ohm

Dimensions: 12.6" W x 20.5" H x 15.75" D

Weight: 33 lbs.

Amplifier

PJB 250watt, class A/B amplifier with digital switch mode power supply.

Frequency Response

Passive and Active input: 40Hz -120KHz

Low Cut Filter: 24dB/Octave at 40Hz.

Maximum Output Power

250 watt RMS

Signal to Noise Ratio

Better than 98 dB (EQ off, Volume on Full.)

Impedance

Passive Input: >4M Ω /22pF

Active Input: >100K Ω /22pF Line

Input: >75K Ω

Pre Amp Line Out: < 2K Ω

Bal. Out: <200 Ω

Levels

Passive Input: 10mV-2.5V

Active Input: 20mV-5V

Pre Amp Out: 1.2V

FX send: 1V

Bal. Line Out: Typical 600mV

Compressor / Limiter

Gain: 0dB

Compression Ratio: 3dB: 1dB

EQ CENTER FREQUENCIES

50, 160, 630, 2.5K, 12K at +/- 18dB

Included Parts

12 ft AC Power Cord

Allen Key

PJB SUPER FLIGHTCASE SIMPLIFIED BLOCK SCHEMATIC

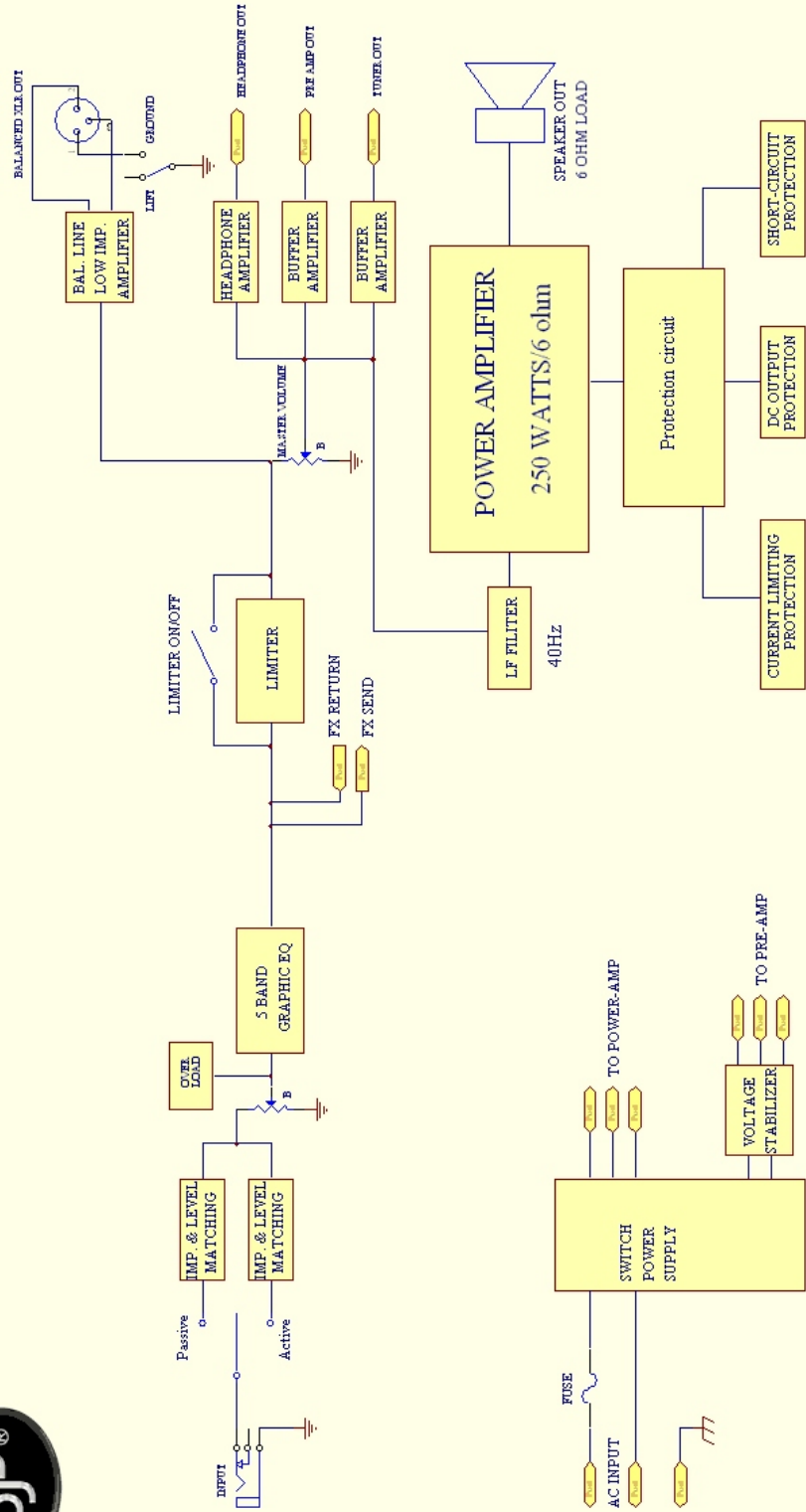

SERVICE/WARRANTY INFORMATION

The SUPER FLIGHTCASE has a warranty period of 2 years, starting from the date of purchase. The buyer must complete and return the enclosed warranty card within 14 days of purchase.

This warranty covers defect in materials or workmanship that occurs in normal use. Within warranty period PJB will repair or replace the defect unit free of labor and parts charge. It is the buyer's responsibility to use the unit strictly according to instructions written in this manual and amplifier manual.

This warranty is not transferable; it is provided to original owner only. Damage/defects caused by the following conditions are not covered by this warranty:

- Improper handling, neglect or failure to operate the unit in compliance with the instructions given in user manual;
- Connection or operation of the speakers in any way that does not comply with the technical or safety regulations applicable in the country where the product is used;
- Repairs or modifications by anyone other than authorized PJB service agent;
- Damages/defects caused by force majeure or any other condition that is beyond the control of PJB.

Should you need any warranty service, please bring the **SUPER FLIGHTCASE** back to the dealer from whom you purchased, along with your sales receipt. Depending on the complexity of the repair work, your dealer may return the defect unit to PJB service center for repair or replacement.

Phil Jones Bass

American Acoustic Development LLC
8559 Page Avenue St. Louis, MO 63114 USA
Phone: 314 814 3383
Fax: 636 536 1338

www.philjonesbass.com

support@philjonesbass.com

Phil Jones Bass is a division of American Acoustic Development LLC.
www.aadsound.com



American Acoustic Development LLC
8559 Page Avenue St. Louis, MO 63114 USA
Phone: 314 814 3383
Fax: 636 536 1338

www.philjonesbass.com

support@philjonesbass.com

Printed in CHINA